

HAMILTON

Microlab[®] 700 Series

Smart Liquid Handling



Content

Microlab® 700 Series
Smart Liquid Handling



Introducing the Microlab 700	4
Dual Syringe Diluters	6
Dispensers	10
Standalone Syringe Pumps	12
Microlab 700 Hardware	14
Microlab Software	16
Controller	18
Universal Valves	20
Bubble Free Prime Syringes	21
Accessories	22
Replacement Parts	24
Specifications	26
About Hamilton	27

Introducing the Microlab[®] 700

The Microlab 700 is a highly precise syringe pump with a new generation touchscreen controller that brings a superior technological solution, an interface designed to quickly and easily dilute and dispense fluids. This positive displacement system provides better than 99% accuracy, independent of a liquid's viscosity, vapor pressure, and temperature. The inert fluid path minimizes sample carryover and is compatible with harsh chemicals.

All Laboratories can use the Microlab 700

Every laboratory has tasks too small to automate and too large to reliably accomplish by hand. The Microlab 700 is a semi-automated liquid handler designed specifically for these in-between applications that increase throughput and consistency while reducing cost and wasted buffer.

Common industries using the product are:

- Pharmaceuticals
- Biotechnology
- In-Vitro Diagnostics
- Forensics
- Food and Beverage Industry
- Dairy Industry
- Environmental Analysis
- Mining Industry
- Textile Industry

Advantages of the new Microlab 700 Controller

- ✓ Innovative possibilities for communication options
- ✓ A full range of peripherals and documentation solutions
- ✓ Remote Diagnostic Support and Analysis
- ✓ Smart data storage
- ✓ Designed for easy integration into LIMS systems
- ✓ Comply with FDA GLP and GMP, 21 CFR Part 11

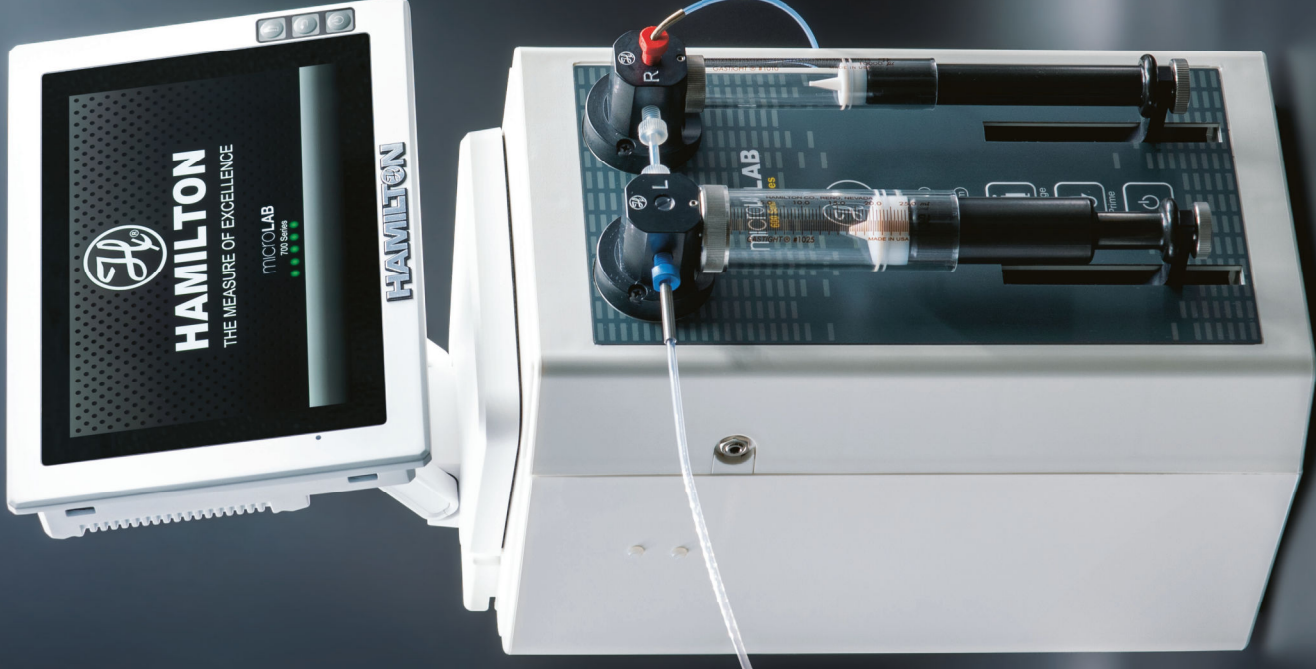

Dual Syringe Diluters

Concorde Hand Probe

The Dual Syringe Diluter configuration uses two syringes to create up to a 1:50,000 dilution in a single step, drastically reducing preparation time and wasted buffer. The diluent washes the tubing between each sample, minimizing carryover for even the most sensitive techniques including:

- Atomic absorption (AA)
- Inductively coupled plasma spectroscopy (ICP)
- High performance liquid chromatography (HPLC)
- Gas chromatography (GC)
- Liquid scintillation

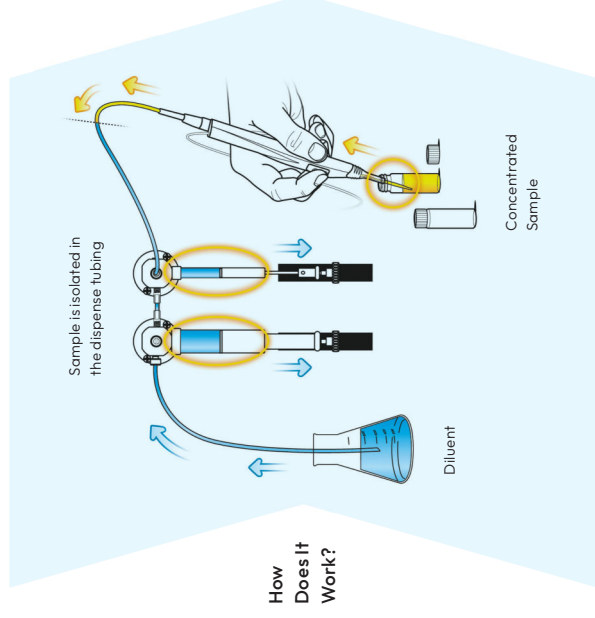

Step 1
Program sample and diluent volume.

Step 2
Trigger the hand probe to fill left syringe with diluent and aspirate sample into the hand probe with the right syringe.

Step 3
Trigger the hand probe to dispense the sample and then the diluent into the vial to complete the dilution and wash the tube for the next sample.

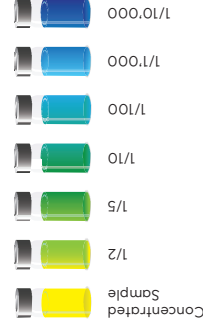

Dilution Wizard

Accurately dilute concentrated samples with diluent over a wide range of dilution ratios.

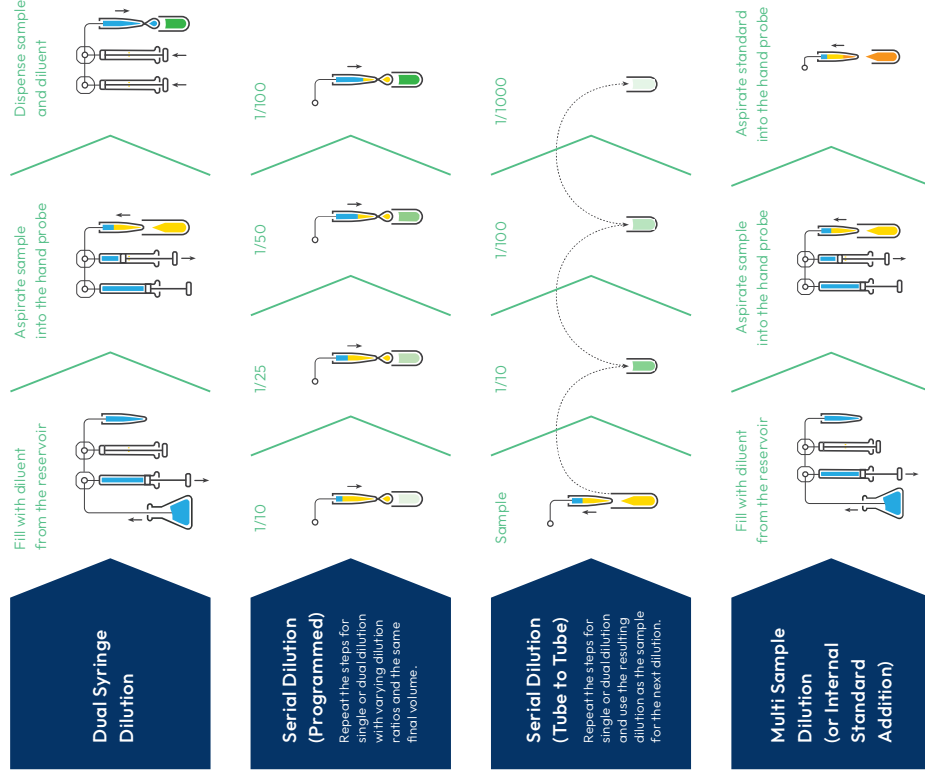

Diluter Ordering Information

Part number	Product name	Description
10103468	ML715-DIL	Dual syringe diluter with Advanced controller
10103471	ML725-DIL	Dual syringe diluter with Premium controller

The -DIL model ships with the Concorde hand probe, universal valves, fill/dispense tubing, accessory holder, country-specific power cord, and the choice of two syringes. If syringes are not selected at the time of the order, 2.5 mL and 250 µL syringes are included.



Disposable Tip Hand Probe (DTHP)

For sensitive applications, the sample is aspirated into a disposable plastic tip which is thrown away between each sample, eliminating any chance for carryover. Applications that benefit from the DTHP include:

- Forensics – for some applications regulatory considerations make disposable tips the preferred option
- Sterile samples – sterile disposable tips can be used to avoid transferring contamination between sample vessels
- DNA amplification – for applications where a single amplified strand of DNA is enough to impact results



Dilution Options



Single Sample Dilution

- 1 The trigger is pressed and the sample is aspirated into the tip using the right syringe while diluent is drawn into the left syringe
- 2 The trigger is pressed again and the sample is dispensed from the tip
- 3 The tip is ejected
- 4 Another trigger dispenses the diluent to complete the dilution



Multi Sample Dilution

- 1 Aspirate Sample 1 into ClickSure Tip
- 2 Aspirate Sample 2. Repeat with additional solutions
- 3 Dispense Samples
- 4 Discard ClickSure Tip
- 5 Dispense Diluent

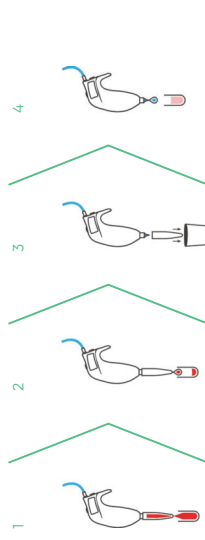

Icon Key

Color Guide

- Sample 1
- Sample 2
- Dispensed Samples
- Diluted Sample
- Diluted Samples

Disposable Tip Hand Probe Ordering Information

Part number	Product name	Description
10103470	ML725-DTHP	Microlab 700 Diluter with Disposable tip Hand probe

ClickSure Tips for DTHP Ordering Information

Part number	Description
2355537	50 µL, non-sterile ClickSure Tips, 960 tips, racked
2355543	50 µL, non-sterile ClickSure Tips, 960 tips, bulk
2355539	1 mL, non-sterile ClickSure Tips, 960 tips, racked
2355545	1 mL, non-sterile ClickSure Tips, 960 tips, bulk

The -DTHP model ships with the Disposable Tip Hand Probe, universal valves, fill tubing, Cable Management System, country-specific power cord, and the choice of two syringes. If syringes are not selected at the time of the order, 2.5 mL and 250 µL syringes are included.

Dispensers

The MicroLab 700 is able to dispense volumes from 100 nL to 50 mL and uses positive displacement syringes to accurately dispense volatile, viscous, and dense liquids independent of atmospheric influences. The inert fluid path is compatible with harsh chemicals, making the MicroLab 700 the most reliable and robust dispensing system available.



Single Syringe Dispenser
The syringe fills from a reservoir and dispenses from the hand probe.

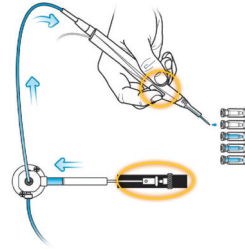

Continuous Dispenser
One syringe fills while the other syringe is dispensing from the same reservoir.

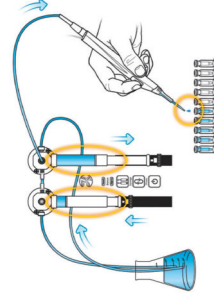

Dual Syringe Dispenser
Each syringe fills from a separate reservoir and dispenses separately from the hand probe.

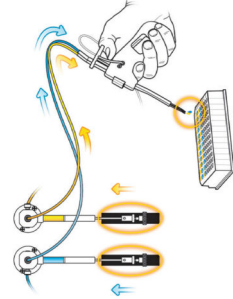

Aliquot Dispense Wizard

Repetitively dispense aliquots of the same volume at the press of a button.

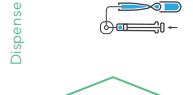
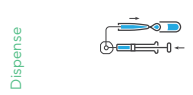
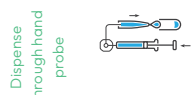
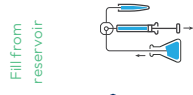

Serial Dispense Wizard

Repetitively dispense aliquots of differing volumes at the press of a button.

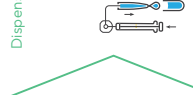
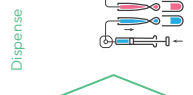

Titration Wizard

Slowly add liquid to another liquid until an end-point is reached. An example of this application is adding acid or base to a pH buffer.



Pipette Wizard

Simulate a manual pipette used to transfer liquid from one vessel to the next.

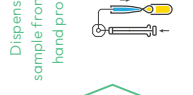
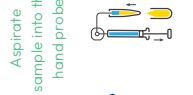

Color Guide

- Reagent 1 / System Fluid
- Reagent 2
- Sample
- Titration Endpoint

Dispenser Ordering Information

Part number	Product name	Description
10103458	ML710-DIS	Single Syringe Dispenser with Advanced Controller
10103460	ML720-DIS	Single Syringe Dispenser with Premium Controller
10103461	ML715-DIS	Dual Syringe Dispenser with Advanced Controller
10103464	ML725-DIS	Dual Syringe Dispenser with Premium Controller
10103465	ML715-CNT	Dual Syringe Continuous Dispenser with Advanced Controller
10103467	ML725-CNT	Dual Syringe Continuous Dispenser with Premium Controller

All dispensers ship complete with a Concorde hand probe (the dual - DIS uses the Dual Push Button hand probe), universal valve(s), fill/dispense tubing assembly, accessory holder, country-specific power cord, and the choice of syringes. If no syringe(s) are selected at the time of the order the -DIS will ship with 1 mL syringe(s) and the -CNT will ship with 10 mL syringes.

Standalone Syringe Pumps

Simple to Integrate

Take full command of your diluting and dispensing applications with the Microlab 700 standalone syringe pump. The standalone syringe pump allows you to custom program methods and deploy commands to any instrument on your network from anywhere in the world, giving you unparalleled control of your process.

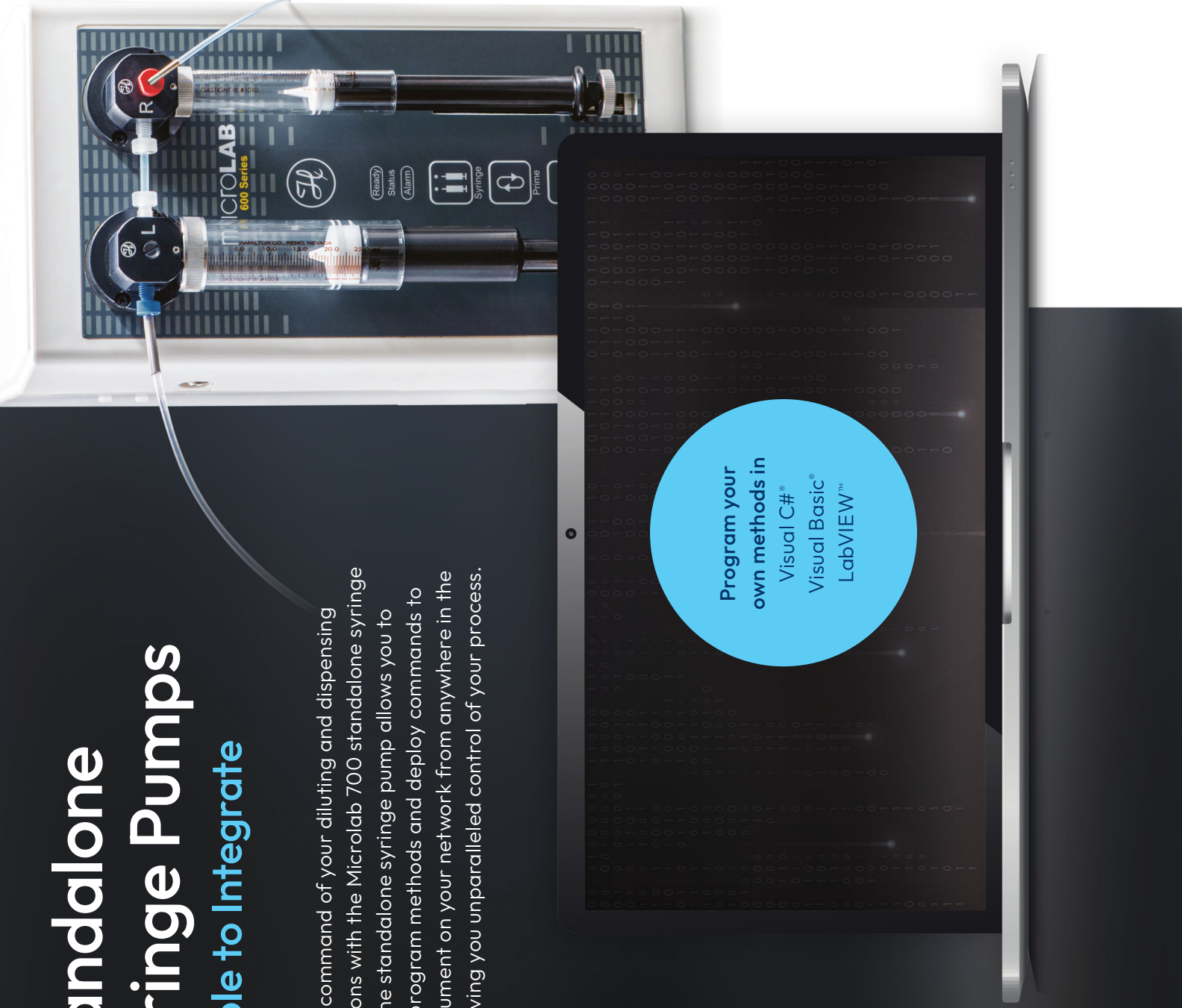

Choose Ethernet or RS-232 Communication

Choose Ethernet Communication if

- The application requires control over all details of the pump like the front LED lights, acceleration speeds, custom initialization routines, etc.
- Remote control or monitoring of the pump is important. This includes dispensing in restricted environments like clean rooms, rooms with high radioactivity, or chemical contamination, etc.
- Development is being done in a Microsoft .NET 2.0 programming environment. The API simplifies programming with on screen help in an industry standard format.

Choose RS-232 Communication if

- The control device is a Programmable Logic Controller.
- The control device is not a PC running Windows® or the programming language is not compatible with Microsoft® .NET 2.0 framework.
- The application has already been implemented using an older RS-232 device like Microlab 500.
- The application requires the use of another Hamilton RS-232 device like Modular Valve Positioner.

Standalone Pump Ordering Information

Part number	Description
ML630	Single Syringe Pump
ML635	Dual Syringe Pump

All standalone pumps ship complete with a universal valve(s), country-specific power cord, Custom Programmer kit, and choice of syringes. If no syringe(s) is/are selected at the time of the order 1 mL syringe(s) will be included automatically.

Microlab 700 Hardware

Controller Features



The Microlab 700 controller features a large, easy-to-use touchscreen with a performant processor, two USB ports for connection of RFID scanner, QR/Barcode scanner, USB flash drive; two RS232 Port for connection of balances, label printer; two Ethernet Ports for connection to Microlab base unit and network.

Microlab 700 Connectors

Connector	Interface	Function
IOIO #1	RS232C COM1	Analytical or precision balance
IOIO #2	RS232C COM2	Label printer, Log printer
Micro SD card slot	Micro SD	Slot for SD cards up to 64 GB
USB-A #1	USB 2.0/host	Slot for micro SD cards up to 64 GB
USB-A #2	USB 2.0/host	RFID-scanner, QR code scanner
RJ-45 #1	LAN-1 100M	Microlab 700 base unit
RJ-45 #2	LAN-2 100M	LAN for intranet and internet
Power Jack IN	24VDC IN	Power input from DC power cable
Power Jack OUT	24VDC OUT, 3A max	Power output for Microlab 700 base unit
Wi-Fi	802.11 a/b/g/n 2.4 GHz	Wireless LAN for intranet and internet
Bluetooth 4.0	2402MHz-2480MHz	Used for accessories in future

Syringe Pump Features

The Microlab 700 is available as a single or dual syringe system. The high torque, precision stepper motors provide unsurpassed positional accuracy across the full range of Hamilton syringes from 10 µL to 50 mL. The instrument communicates with the controller or a corporate network via an Ethernet port. Serial communication via RS-232 is also possible for programming in a non Windows® environment.



Microlab Label Printer



Microlab Digital Scanner



Microlab RFID Reader

Controller Accessories

Part number	Product name
10106736	Microlab RFID Reader
10106738	Microlab Digital Scanner
10106739	Microlab Label Printer*
10106806	Labels for Microlab Label Printer

* Power supply cord will be selected from page 24



- 1 High torque valve motors
- 2 Precision syringe drives with 48000 step resolution over 60 mm
- 3 Illuminated power and prime buttons
- 4 Independent left and right trigger ports
- 5 Fanless heat vent
- 6 24 volt power input
- 7 CAN daisy chain input/output
- 8 RS-232 console port
- 9 Power over Ethernet (PoE)
- 10 TTL input/output

Microlab Software

Advanced Controller Software

The controller is ideal for completing simple diluting and dispensing tasks. Quickly set the desired volume in the Quick Start Run Screen and begin.

New utilities

-  **New Utility Menus**
 - Easy to access and human readable error log
 - Audit Trail viewer
 - Update software via internet
 - Update software via USB flash drive / SD card
 - Log Viewer: Logs can be opened with PDF viewer, directly on the controller screen
 - Possibility to create a full encrypted system backup and device specific (protected to access only for a specific device)
 - Restore function

New user support

-  **New Help Menu**
 - Send emails to customer support directly from device
 - Read user manual directly from device
 - Screen sharing (Remote control)
 - Tutorial videos
 - Easier understanding of the Microlab platform functionalities through the new help menu

NEW configurations

-  **New LyncStore 700 Menu**
Premium Version only
 - Add LyncStore Account
 - Sync Log files
 - Sync Audit Trail
 - Sync Custom Methods
 - Sync Favorite Methods (created by means of the existing Wizards)
 - Allow Remote Access

New Communication Menu

- Manage WLAN
- Manage LAN
- Manage external devices & accessories

New GLP Printer Menu

- Configure GMP/GLP complaint print content (Protocol Printer)

New Security Settings

- Multiple Administrator accounts
- Enable Audit Trail Dialogs (Parameter change must be justified)
- Enable PDF signatures
- Automatic sign out after X minutes
- Sign-in with RFID card

Updated Wizard

-  **Dry Weight Dilution 2.0**
 - Improved usability
 - Save to favorites
 - Support of many balance models (Mettler, Sartorius, Kern, Ohaus)

New cleaning Features

-  **Cleaning features**
 - Cleaning reminder (time period-based)
 - Cleaning reminder (cycle count based)
 - Auto reset of reminder after cleaning

Maintenance

- Maintenance features**
 - Error statistics
 - Maintenance reminder (date-based)
 - Maintenance warning (time period-based)

Simple Diluting

Diluent is drawn by the left syringe and sample is drawn into the tubing by the right syringe.

Both syringes dispense to complete the dilution.

Simple Dispensing

Solvent is drawn into the syringe and dispensed out through the hand probe.

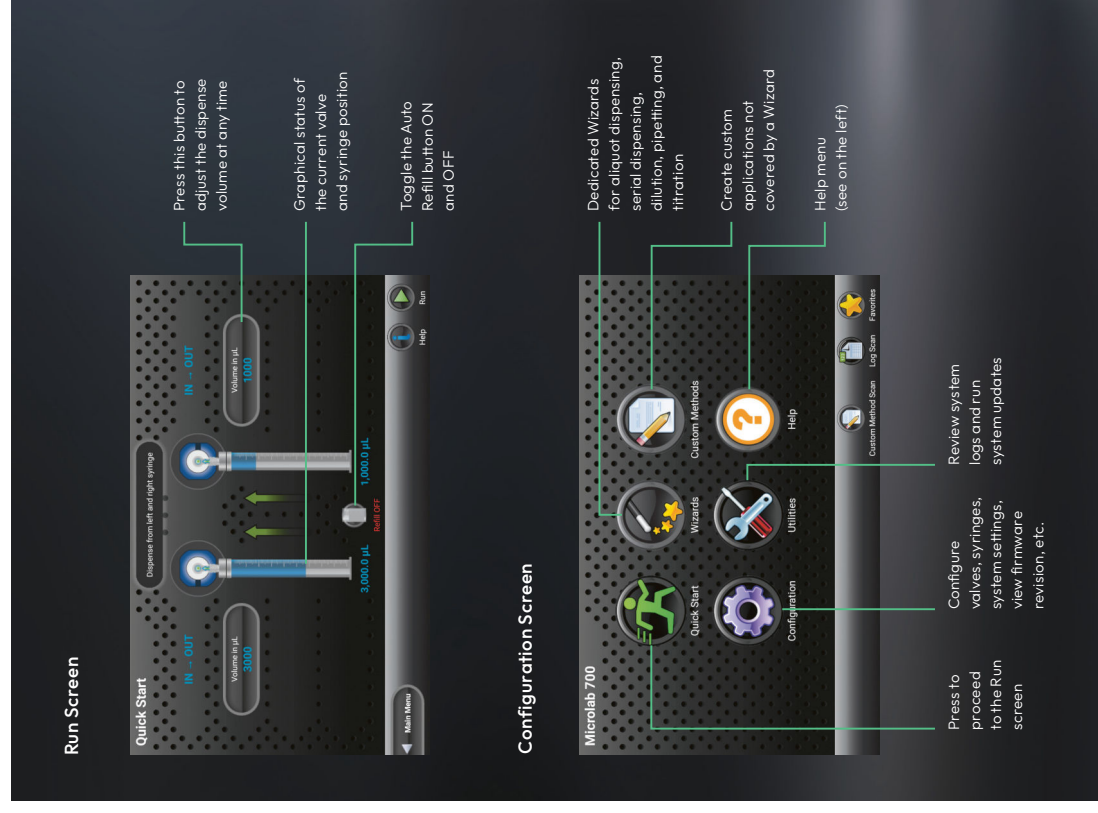

Controller



Compliance and Logging

The software provides a variety of security protections, simplifies adherence to FDA GXP regulations, ability to administer user accounts and passwords, create log files that conform to 21 CFR Part 11 and manage log files on a PC using the LyncStore application.



Language Support

The Microlab 700 features language support for English, Spanish, German, French, Italian, and Chinese.



Archiving and Sharing Methods

Favorites and Custom Methods are stored on the Internal Storage or external: USB, microSD or remotely by LyncStore connectivity.

Wizards

Wizards are designed to simplify the programming of common everyday methods. The controller ships with the most popular Wizards installed but it is simple to add or delete Wizards from the menu. Visit www.hamiltoncompany.com/microlabwizards to see a complete list of available Wizards.

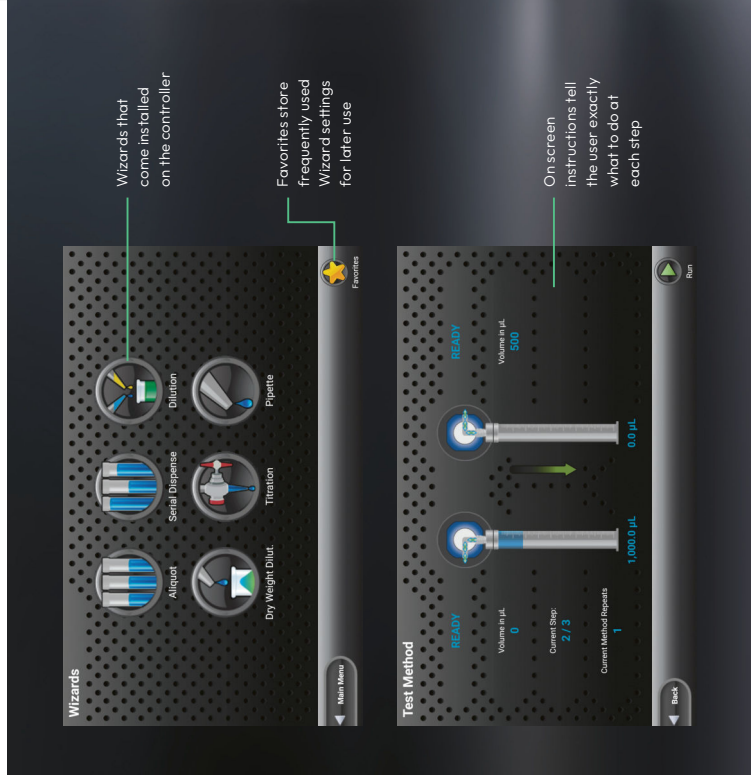

Custom Methods

Custom methods can be created to accomplish unique liquid handling tasks. Incorporate loops, delays, external triggering, and execution counters with valve and syringe movements to create complex methods.



Premium Configuration

LyncStore 700 features

- Best-Practice API documentation with swagger
- Compliant with 21 CFR Part 11
- API comes with a web interface
- Realtime access to Microlab 700
- Automatic data backup
- Remote control

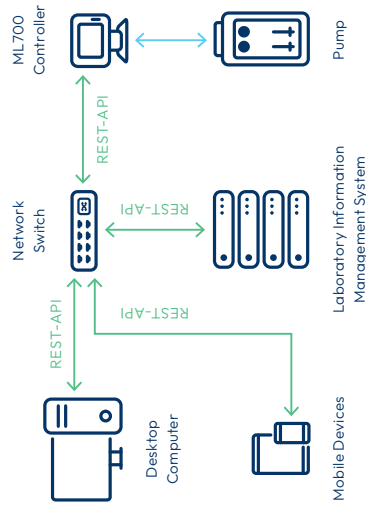

Universal Valves

Innovative fluid logic allows the same universal valve to be used in all Microlab 700 diluting and dispensing applications. Interchange the valve plugs and tubing to achieve the following configurations in a matter of minutes.

Valve Plumbing Based on Instrument Configuration:

Dual Syringe Diluter

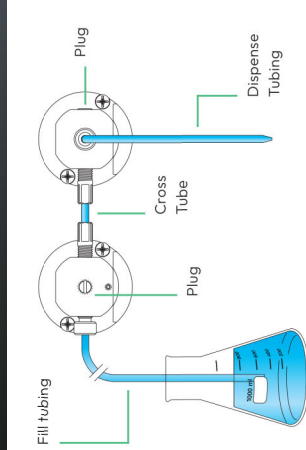

Single Syringe Dispenser

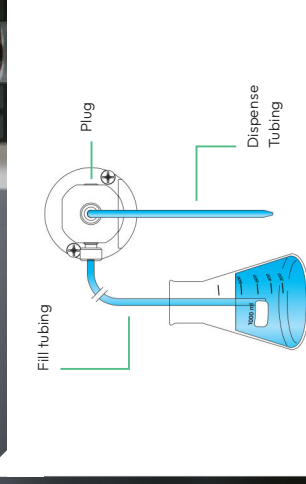

Dual Syringe Dispenser

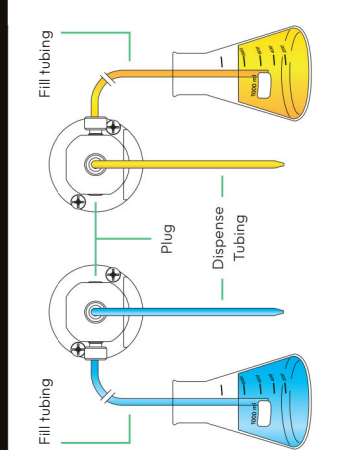

Continuous Dispenser

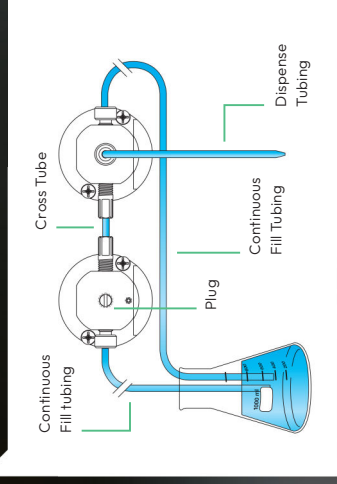

Bubble Free Prime Syringes

For any syringe pump, the key to achieving the most accurate dispenses is eliminating all air from the fluid path. Traditional syringes trap approximately 50 μL of air between the tip of the syringe and the valve. For small syringes, this trapped air is the last to leave the syringe and the first to be drawn back in, making them difficult if not impossible to prime.

The Bubble Free Prime syringe has a conical plunger tip that extends through the threaded termination and into the valve. This unique design expels the air from the syringe and valve decreasing the number of priming cycles required.

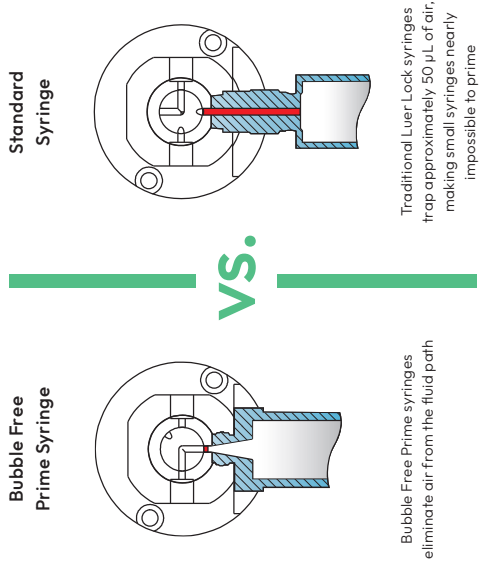

Traditional Luer Lock syringes trap approximately 50 μL of air, making small syringes nearly impossible to prime

Bubble Free Prime syringes eliminate air from the fluid path

Color Guide

- Trapped Air
- Syringe
- Plunger

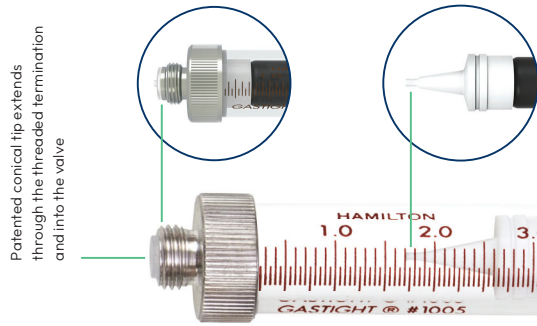

Patented conical tip extends through the threaded termination and into the valve

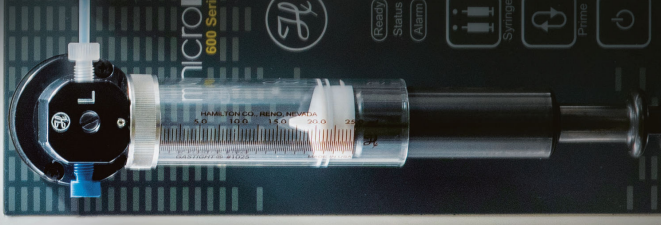

Accessories

Protect Your Investment with AirShield

The AirShield is a separate accessory that can be purchased for any MicroLab 700 instrument. It creates a positive pressure blanket of fresh air inside the pump that pushes air out over critical components on the outside of the pump, protecting them from the environment.

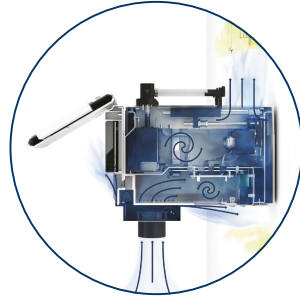

Localized Harsh Environment

In many labs the air is relatively clean but samples and reagents placed near the instrument result in a localized environment that can be harmful. For these labs, it is sufficient to source clean air from the back of the instrument away from the microenvironment.

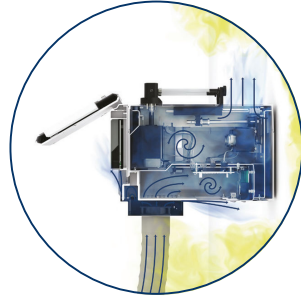

Optional Snorkel for Fresh Air Supply

For labs with a more demanding atmosphere it is possible to source clean air via a snorkel that connects directly to the AirShield. Fresh air is then brought from outside the harmful environment to create a shield of clean air around all critical instrument components.



Luer Lock Conversion Kit
P/N 10150621

Concorde CT Hand Probe
Standard with the Single Syringe Dispenser, Dual Syringe Diluter, and Continuous Dispenser



Dual Push Button Hand Probe
Standard with the Dual Syringe Dispenser



Disposable Tip Hand Probe
0.5–1000 µL



Large Volume Disposable Tip Hand Probe
1–5 mL

Hand Probes, Foot Switch, and Printer Kit



Foot Switch

Accessories

Part number	Product name
61401-01	Concorde CT Hand Probe
62541-01	Dual Push Button Hand Probe
63960-02	Disposable Tip Hand Probe (0.5–1000 µL)*
62575-01	Large Volume Disposable Tip Hand Probe (1–5 mL)
75702	5 mL Disposable Tips (250/pkg)
62576-01	Foot Switch
68562-01	AirShield
94939-01	AirShield Tubing (includes tubing clamp)
10150621	Luer Lock Conversion Kit

* Tips for this probe can be found on page 8

Replacement Parts

Syringes and Power Supplies





Standard Syringes

Part Number	Syringe Size	Optimal Range
59000-05	10 µL	1–10 µL
59000-10	25 µL	2.5–25 µL
59000-15	50 µL	5–50 µL
59000-20	100 µL	10–100 µL
59000-25	250 µL	25–250 µL
59000-30	500 µL	50–500 µL
59000-35	1.0 mL	100 µL–1.0 mL
59000-40	2.5 mL	250 µL–2.5 mL
59000-45	5.0 mL	500 µL–5.0 mL
59000-50	10.0 mL	1–10.0 mL
59000-55	25.0 mL	2.5–25.0 mL
59000-60	50.0 mL	5–50.0 mL

SaltLine Syringes

Part Number	Syringe Size	Optimal Range
208335	1 mL	100 µL–1.0 mL
208336	5 mL	500 µL–5.0 mL
208337	10 mL	1–10.0 mL

Power Supply & Power Cords

Part Number	Description	Diagram of Plug
61092-01	Power Supply Universal (110–220 VAC)	
355234	Continental Europe, Russia, Schuko	
355235	Switzerland	
355236	USA, Canada, Mexico, Central America, Brazil, Japan	
355237	UK, Ireland, Malaysia, Middle East	
355238	Australia, New Zealand, Argentina, China	

Selecting a Syringe

Select the smallest syringe with a maximum volume that is greater than the largest volume to be dispensed. Ideally the smallest volume to be dispensed should fall within the optimal ranges listed to the left. The Microlab 700 can dispense volumes below the optimal range but there will be some impact on accuracy and precision. The SaltLine Syringes should be used when working with solutions that have a high salt concentration. Contact a Hamilton sales representative for additional assistance.

Power Cord



Power Supply

Miscellaneous Accessories

Universal Valves & Accessories

Part Number	Valve Assembly Description
60676-01	Left Valve Assembly
60675-01	Right Valve Assembly
61498-01	Valve Cross Tube Assembly
61729-01	Valve Plug (1/pk)

FEP Tubing Assemblies

Part Number	Gauge	Type	Length	Internal Volume
10106145	18	Fill Tubing	48" (1219 mm)	0.96 mL
10106147	18	Dispense Tubing	54" (1372 mm)	1.08 mL
10106177*	18	Fill/Dispense Tubing	Custom Length	0.79 µL/mm
10106148	12	Fill Tubing	48" (1219 mm)	3.83 mL
10106149	12	Dispense Tubing	54" (1372 mm)	4.31 mL
10106177*	12	Fill/Dispense Tubing	Custom Length	3.14 µL/mm
61491-02	18	Continuous Fill Tubing		0.79 µL/mm
61491-01	12	Continuous Fill Tubing		3.14 µL/mm

Activation Key

Part Number	Upgrade Kit
10101502	ML700 Premium Activation Key

Other Accessories

Part Number	Valve Assembly Description
88990	Tubing Clips (5/pk)
61710-01	Accessory Holder & Tubing Wire Stand
6609688-01	Base Plate



Left Valve



Right Valve



Valve Plugs



Cross Tube



Fill & Dispense Tubing

Dispense tubing has tapered end



12/18 Gauge Tubing

The red color represents the gauge 12 tubing



Wire Stand



Base Plate



Tubing Clips



Accessory Holder

Specifications

Controller Specifications	
System Configuration	CPU NXP i.MX 6DualLite 800MHz ARM Cortex-A9 processor RAM: 1 GB DDR3, ROM: 8 GB GPU 3D Vivante GC680 35Mtri/s 266Mpxl/s OpenGL ES 2.0 OS: Android 5.1.1 / Linux Debian 8.0
Media	Video Decode 1080p30 + D1 Video Encode 1080p30 H.264 BP / Dual 720p
Interface	Micro SD (TF) card slot, support up to 64G USB Device 2.0(OTG)x1, USB host 2.0x2 IOIO1 (COM1 COM4 COM5) IOIO2 (COM2 RS422 RS485) LAN1 100M LAD2 200M, PoE for optional Earphone jack
Function	DC power input & output Wi-Fi 802.11a/b/g/n 2.4 GHz
Touch Panel	Capacitive
Display	7" LED backlight Screen Resolution: 1280 x 800 Brightness: 400cd/m2 Contrast: 800:1 Viewing Angle: 140°/160° (H/V)
Power supply	DC 9-36V
Power Consumption	≤10W (Normal mode)
Temperature	Working: -20°C - 60°C Storage: -30°C - 70°C
Dimension	206 x 144 x 30.9 mm
Weight	790g

Single and Dual Syringe Pump Specifications	
Accuracy	±/-. 1%
Precision	±/-. 0.2%
Syringe drive mechanism	1.8° stepper motor with variable volumetric flow rate
Flow rate	0.003-6000 µL/second (depending on the syringe that is selected)
Syringe resolution	0.002% of the nominal syringe volume
Compatible syringes	10, 25, 50, 100, 250, 500 µL, 1, 2.5, 5, 10, 25, and 50 mL BFP Syringes
Volume range	1.0 µL-50 mL
Fluid path	Borosilicate, PTFE, C TFE
Communication type	Ethernet, 10/100 BASE-T
Communication protocol	.NET 2.0 Application Programming Interface (API)
Pump memory	One method stored in non volatile memory
Calibration	Factory tested and traceable to N.I.S.T. standards
Certifications	CE
Power requirements	100-240 V 1.5 A max 501.60 Hz
Power rating	24 VDC, 2.5 A
Dimensions	7 x 5.5 x 10.5 inch (177.8 x 139.7 x 266.7 mm)
Weight	13 lbs (5.9 kg)

About Hamilton

Innovation for a better world

Hamilton Company specializes in the development, manufacturing, and customization of precision measurement devices, automated liquid handling workstations, and sample management systems. Hamilton's processes are optimized for quality and flexibility. Whether it's a custom needle with a quick delivery timeframe, a special length pH sensor, or a comprehensive solution to fully automate your assay workflow, trust that Hamilton's products will always meet your needs.



Storage
Hamilton Storage offers ultra-low temperature automated sample management systems for storage of a variety of labware. Hamilton's line of biobanking and compound management systems, benchtop devices, and consumables are designed for sample integrity, flexibility, and reliability.



Process Analytics
Hamilton Process Analytics includes innovative solutions for the online measurement of pH, dissolved oxygen, conductivity, ORP, viable cell density, and total cell density. Hamilton's proprietary Arc® intelligent sensor technology eliminates the need for transmitters and moves the functionality to your smartphone or tablet.



OEM Solutions
Many of the world's top manufacturers utilize Hamilton products and expertise to get their innovations to market faster with lower development and manufacturing costs. As an OEM partner, we offer the ability to integrate our proven syringe pumps or pipetting channels, customize our proven liquid handling platforms, or design a complete system to automate your novel chemistry.



Laboratory Products
Hamilton Laboratory Products manufactures Microaliter™ and Gasight® syringes that set the standard for analytical fluid measurement. Other products include custom needles, semi-automated diluters and dispensers, polymeric HPLC columns, pH electrodes, pipettes, and more.



Robotics
Hamilton Robotics provides automated liquid handling workstations and laboratory automation technology for the scientific community. With a focus on innovative design, our products incorporate Hamilton's patented liquid handling technologies for fully automated solutions. In addition to liquid handling platforms, we also offer application-specific solutions, small devices, and consumables.

Hamilton Company has been a leading global manufacturer for more than 60 years, with headquarters in Reno, Nevada; Franklin, Massachusetts; Timișoara, Romania; and Bonaduz, Switzerland; and subsidiary offices throughout the world.

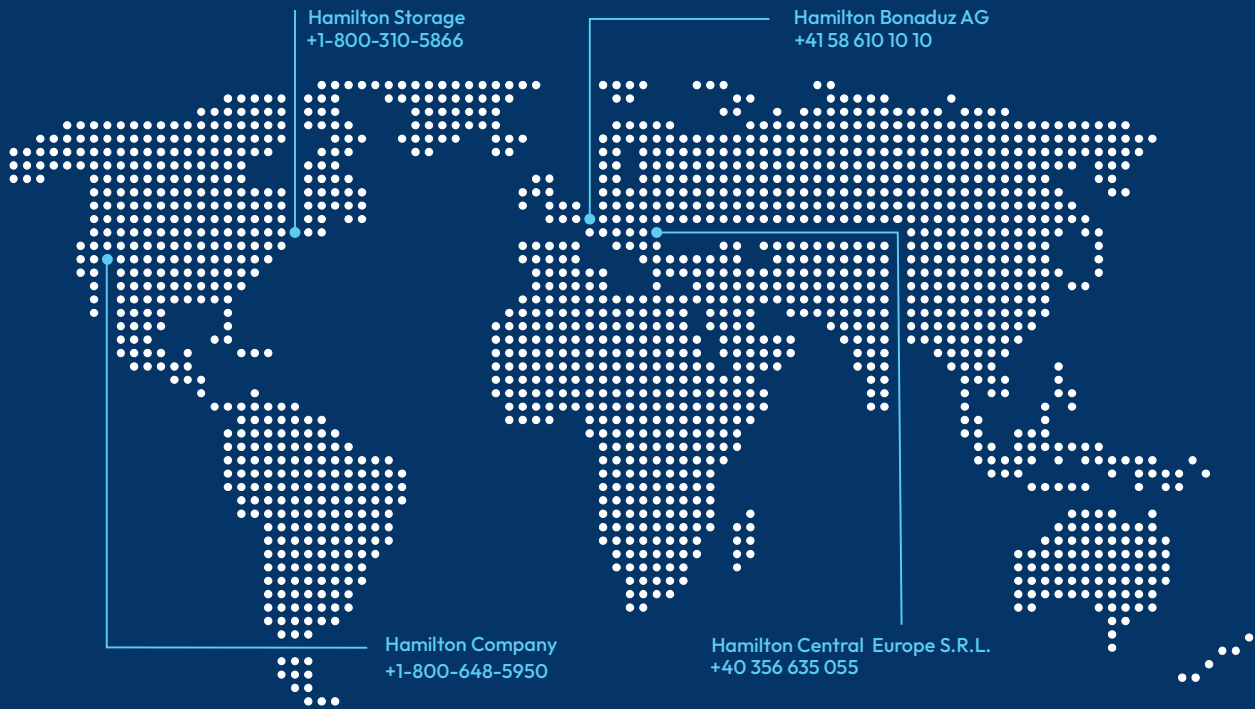

● Headquarters / Manufacturing



Years of Experience
75+



Locations Worldwide
22+



Employees Internationally
3,000+

To find a representative in your area, please visit:

hamiltoncompany.com/contact
contact.hce.ro@hamilton-ce.com

Hamilton Europe, Middle East, Asia & Africa
Hamilton Central Europe S.R.L.
str. Hamilton no. 2-4
307210 Giarmata, Romania
Tel: +40-356-635-055
contact.hce.ro@hamilton-ce.com

